

Analysis of Primary and Secondary Lateral Suspension System of Railway Vehicle

**Mohd Hanif Harun*

W Mohd Zailimi W Abdullah

Faculty of Mechanical Engineering

Universiti Teknikal Malaysia Melaka

76100 Durian Tunggal, Melaka

Email: hanif@utem.edu.my

Hishamuddin Jamaluddin

Roslan Abd. Rahman

Faculty of Mechanical Engineering

Universiti Teknologi Malaysia, 81310 Skudai, Johor

Khisbullah Hudha

Faculty of Engineering

Universiti Pertahanan Nasional Malaysia

Kem Sungai Besi, 57000 Kuala Lumpur, Malaysia

ABSTRACT

The aim of this paper is to study the effect of primary and secondary suspensions of a railway vehicle on stability and passenger ride comfort. The possible improvement of conventional suspension without using a controllable suspension system is investigated. A linear 17 degree-of-freedom (DOF) railway vehicle model is used to study the vibration response of the railway vehicle body. The equations of motion that represent the dynamics of the railway vehicle were derived based on Newton laws to describe the lateral, yaw and roll motions of the vehicle body, bogies and also wheel-sets. The spring stiffnesses and damping coefficients of the primary and secondary suspensions were varied incrementally in order to observe the response of the railway vehicle body. The vehicle model was simulated with lateral sinusoidal track disturbance using Matlab-SIMULINK software. The simulation results showed that the railway

vehicle stability is significantly affected by the values of primary suspension, and body ride quality is affected by secondary suspension elements.

Keywords: *Primary suspension, secondary suspension, railway vehicle model, lateral disturbance*

Introduction

The suspension system in automotive and railway vehicle is designed to offer good ride comfort, safe speed and stability to drivers and passengers and has become an important engineering problem to be solved [1]. The suspension in rail transportation system has been categorized as a very complex system since it has two levels of suspension namely the primary and secondary suspensions. Each suspension level consists of three axis suspensions which are the longitudinal, lateral and vertical suspension systems. Longitudinal response of the primary and secondary suspensions normally react to yawing motion occurred at the bogies and body of the railway vehicle. Lateral suspensions react to swaying and yawing motion, and at the same time will act to prevent vehicle body to roll. Meanwhile, the vertical suspension system is used react to the responses due to vertical motion such as rolling, pitching and also vertical body acceleration. The control mechanism of the vertical motion must cope with variable static loads due to the vehicle payload [2].

In railway vehicle suspension system, there are three types of suspension system and can be categorized based on the location of the suspension component namely primary suspension, secondary suspension and tilting system. The main task of primary suspension is to satisfy vehicle's stability and guidance requirement, meanwhile the soft secondary suspensions is to provide a good ride quality and isolation from the track-induced vibration which is the main focus in this study. The secondary suspension is located between bogie and vehicle body. Meanwhile, tilting system is particular of a secondary suspension which aims to improve the ride quality by applying full active control at the secondary roll suspension or anti roll bar.

Various studies have been done by engineers, researchers and academicians on railway vehicle dynamics. The researches generally focused on vibration reduction by applying semi-active or active system to the primary or secondary suspension system. Successful recent works have been reported on railway vehicle dynamic behaviour using semi-active damper which replace conventional dampers located at the secondary stage of suspension [3-6]. Active suspension systems have been shown to reduce vibration significantly as reported by [7-10].

With the emergence of increased computing power, the developments of advanced railway vehicle suspension systems have been investigated based

on more complex vehicle models. Another effort at improving the dynamic performance of the railway vehicle has been carried on the primary suspension system by [11] and the results of the study showed that critical hunting velocity is most sensitive to the stiffnesses of both primary longitudinal and lateral suspensions. Gao and Yang [12] studied a semi-active lateral suspension systems which showed improvement in ride comfort and also attenuated vibration of the car body. Another contribution to vibration reduction was done by Sugahara [13] by controlling the damping force of the axle dampers which form a damping element of the primary suspension, and by suppressing vertical vibration of the bogies. Investigation on semi-active and passive suspension systems for railway vehicle has increased recently due to the abilities of these types of suspension to suppress unwanted vibration. Although they promise to present a better control to the unwanted vehicle vibration, they also have several limitations with respect to conventional passive system. For example, the high cost of development semi-active or active systems coupled with the increase complexity of the system and higher maintenance requirements. The purpose of this paper is to investigate the possible improvement to a conventional suspension without using a controllable suspension system.

In this paper, the effect of the primary and secondary suspensions on railway vehicle stability and quality are compared by evaluating the response of the vehicle body in terms of body displacement, body yaw angle and body roll angle when disturbed by 0.05 m lateral sinusoidal track amplitude with 1 rad/sec excitation. The spring stiffnesses and damping coefficients of primary and secondary suspensions were varied incrementally. The finding from this paper shows which suspension element plays an important role in reducing the unwanted vehicle body motion when the train runs on a track with lateral track irregularity. The knowledge from this study will be used for semi-active or active control in future research.

Railway Vehicle Model

The analytical dynamic model of a railway vehicle with two stages of suspension namely primary and secondary, is derived and developed in particular for the dynamic analysis of a commuter rail vehicle running on track that has lateral irregularities. A schematic representation of the commuter rail vehicle with a 17-DOF vehicle model consisting of vehicle body, two sets of bogie and four wheel-sets is shown in Figure 1.

Analytical model

Some of the assumptions considered in this model are as follows: the vehicle body, bogies and wheel-sets are considered as rigid and aerodynamic drag force is ignored. The suspension components between vehicle body and bogies

are modelled as a passive secondary system with viscous dampers and spring elements in vertical, lateral and longitudinal directions, while the components of viscous damper and spring elements between the bogies and wheel-sets are modelled as a primary suspension system. Rolling resistance due to an anti roll bar and body flexibility is also neglected. The wheel-sets move along a straight rail at a certain constant velocity and the track alignment irregularity is regarded as the external excitation to the railway vehicle system. Lateral irregularities normally occur when both rail lines have some displacement laterally with respect to the original track due to prolonged exposure to sun's heat [14], or also arise from specific features such as switch and crossing elements of the track [15]. The governing equations are then developed in MATLAB-Simulink tools to perform the vehicle response calculations based on the railway vehicle model as shown in Appendix 1.

Equation of motions

The equations of motion of railway vehicle are developed based on 1:10 scaled model of a commuter rail vehicle that has been fabricated in the laboratory (See Appendix 1). These equations were derived using Newton's Law. By performing balance analysis, the governing equations of lateral, yaw and roll motions of the wheel-sets based on Appendix 1 can be expressed as follows:

$$\begin{aligned}
 m_w \ddot{y}_{wj} &= -2k_{1y}(y_{wj} - y_{bi} - L_1 \psi_{bi} - h_4 \theta_{bi}) \\
 &\quad - 2c_{1y}(\dot{y}_{wj} - \dot{y}_{bi} - L_1 \dot{\psi}_{bi} - h_4 \dot{\theta}_{bi}) \\
 &\quad - 2f_{22} \left(\frac{y_{w1}}{v} - \psi_{wj} \right) + k_g \cdot y_{wj} + 2 \left(\frac{f_{22}}{v} \right) \xi + k_g \cdot \xi + w\rho
 \end{aligned} \tag{1}$$

$$\begin{aligned}
 I_{w_y} \ddot{\psi}_{wj} &= -2k_{1y}(\psi_{wj} - \psi_{bi}) - 2c_{1y}(\dot{\psi}_{wj} - \dot{\psi}_{bi}) \\
 &\quad - 2f_{11} \left[\left(\frac{b\lambda}{r_0} \right) y_{w1} + \left(\frac{b^2}{v} \right) \dot{\psi}_{wj} \right] - c_g \psi_{wj} \\
 &\quad - 2f_{11} \left(\frac{b^2}{v} \right) \ddot{\xi} + c_g \cdot \dot{\xi} + 2 \left(\frac{f_{11} \lambda b}{r_0} \right) \xi
 \end{aligned} \tag{2}$$

where $j = 1, 2$ are the wheel-sets of front bogie $i = 1$, and $j = 3, 4$ are the wheel-sets of rear bogie $i = 2$; m_w is the mass of wheel-sets; I_{w_y} is the yaw moment-of-inertia of the wheel-sets; y_w and y_b are the wheel-sets and bogies lateral displacements; k_{1y} is the primary lateral spring stiffness; c_{1y} is the primary lateral damping coefficient; ψ_w and ψ_b are the yaw angles of wheel-sets and bogies, θ_b is the roll angle of bogies; L_1 is the half distance between two wheel-sets for each bogie; f_{11} and f_{12} are the longitudinal and lateral creep force coefficients; ρ is the horizontal track irregularities of wheel-sets; v is the velocity if railway

vehicle; λ is the tyre slip ratio of the wheel-sets; ζ is the lateral irregularities of track under wheel-sets; w is the axle mass and b is the wheel-sets spacing.

The governing equations of motion of lateral, yaw and roll motions of leading and trailing bogie can be derived as:

$$\begin{aligned}
 m_b \ddot{y}_{bi} = & 2\bar{k}_{1y} (y_{wj} + y_{w(j+1)} - 2y_{bi} - 2h_4\theta_{bi}) \\
 & + 2c_{1y} (\dot{y}_{wj} + \dot{y}_{w(j+1)} - 2\dot{y}_{bi} - 2h_4\dot{\theta}_{bi}) \\
 & - 2k_{2y} (y_{bi} + y_c - h_3\theta_{bi} - L\psi_c - h_1\theta_c) \\
 & - 2c_{2y} (\dot{y}_{bi} + \dot{y}_c - h_3\dot{\theta}_{bi} - L\dot{\psi}_c - h_2\dot{\theta}_c)
 \end{aligned} \tag{3}$$

$$\begin{aligned}
 I_{by} \ddot{\psi}_{bi} = & 2k_{1y} (\psi_{wj} + \psi_{w(j+1)} - 2\psi_{bi}) + 2c_{1y} (\dot{\psi}_{wj} + \dot{\psi}_{w(j+1)} - 2\dot{\psi}_{bi}) \\
 & - 2k_{2y} (\psi_{bi} + \psi_c) + 2k_{1y} L_1 (y_{wj} - y_{w(j+1)} - 2L_1\psi_{bi}) \\
 & + 2c_{1y} L_1 (\dot{y}_{wj} - \dot{y}_{w(j+1)} - 2L_1\dot{\psi}_{bi}) - 2c_{2y} (\dot{\psi}_{bi} + \dot{\psi}_c)
 \end{aligned} \tag{4}$$

$$\begin{aligned}
 I_{bz} \ddot{\theta}_{bi} = & -4k_{1z}\theta_{bi} - 4c_{1z}\dot{\theta}_{bi} - 2k_{2\theta}(\theta_{bi} - \theta_c) - 2c_{2\theta}(\dot{\theta}_{bi} - \dot{\theta}_c) \\
 & + 2k_{2y}h_3(y_{bi} - h_3\theta_{bi} - y_c - L\psi_c - h_1\theta_c) \\
 & + 2c_{2y}h_3(\dot{y}_{bi} - h_3\dot{\theta}_{bi} - \dot{y}_c - L\dot{\psi}_c - h_2\dot{\theta}_c) \\
 & + 2k_{1y}h_4(y_{wj} + y_{w(j+1)} - 2y_{bi} - 2h_4\theta_{bi}) \\
 & + 2c_{1y}h_4(\dot{y}_{wj} + \dot{y}_{w(j+1)} - 2\dot{y}_{bi} - 2h_4\dot{\theta}_{bi})
 \end{aligned} \tag{5}$$

m_b is the body mass; k_{2y} is the secondary lateral stiffness of the suspension; I_{by} and I_{bz} are the yaw and roll moment-of-inertia of the bogies; c_{2y} is the secondary lateral damping coefficient of the suspension; $k_{2\theta}$ and $c_{2\theta}$ are the vertical spring stiffness and damping coefficient of the secondary suspension; h_1 is the height from centre of body mass to the upper line of second spring; h_2 is the height from centre of body mass to central lateral damper; h_3 is the height from the upper line of second spring to centre of sprung mass of bogie; h_4 is the height from centre of sprung mass of bogie to the centre line of wheel-sets; h_5 is the height from centre of sprung mass of bogie to central lateral damper; L is the distance between the central line of the bogie and vehicle body; L_1 is the distance between central line of the bogie and wheel-sets; ψ_c and y_c are the yaw angle and lateral displacement of car body respectively.

Finally, the equations of motion of the railway vehicle car body can be expressed as follow:

$$m_c \ddot{y}_c = 2k_{2y}(y_{b1} + y_{b2} - h_3\theta_{b1} - h_3\theta_{b2} - 2y_c - 2h_1\theta_c) + 2c_{2y}(\dot{y}_{b1} + \dot{y}_{b2} - h_3\dot{\theta}_{b1} - h_3\dot{\theta}_{b2} - 2\dot{y}_c - 2h_1\dot{\theta}_c) \quad (6)$$

$$I_{cy} \ddot{\psi}_c = 2k_{2x}(\psi_{b1} + \psi_{b2} - 2\psi_c) + 2c_{2x}(\dot{\psi}_{b1} + \dot{\psi}_{b2} - 2\dot{\psi}_c) + 2k_{2y}L(y_{b1} - y_{b2} - 2L\psi_c) + 2c_{2y}L(\dot{y}_{b1} - \dot{y}_{b2} - 2L\dot{\psi}_c) \quad (7)$$

$$I_{cz} \ddot{\theta}_c = 2k_{2z}(\theta_{b1} + \theta_{b2} - 2\theta) + 2c_{2z}(\dot{\theta}_{b1} + \dot{\theta}_{b2} - 2\dot{\theta}) + 2k_{2y}h_1(y_{b1} + y_{b2} - h_3\theta_{b1} - h_3\theta_{b2} - 2y - 2h_1\theta) + 2c_{2y}h_2(\dot{y}_{b1} + \dot{y}_{b2} - h_5\dot{\theta}_{b1} - h_5\dot{\theta}_{b2} - 2\dot{y} - 2h_2\dot{\theta}) \quad (8)$$

The degrees-of-freedom of the full railway vehicle model used in this study are listed in Table 1. This table describes the lateral, yaw and roll motions of the railway vehicle with the total of seventeen degrees-of-freedom (17DOF).

Table 1: Railway vehicle model with degrees-of-freedom

Railway vehicle components	Type of motion		
	Lateral	Yaw	Roll
Wheel-set 1 ($j = 1$), front bogie ($i = 1$)	y_{w1}	ψ_{w1}	-
Wheel-set 2 ($j = 2$), front bogie ($i = 1$)	y_{w2}	ψ_{w2}	-
Wheel-set 3 ($j = 3$), rear bogie ($i = 2$)	y_{w3}	ψ_{w3}	-
Wheel-set 4 ($j = 4$), rear bogie ($i = 2$)	y_{w4}	ψ_{w4}	-
Front bogie (leading bogie)	y_{b1}	ψ_{b1}	θ_{b1}
Rear bogie (trailing bogie)	y_{b2}	ψ_{b2}	θ_{b2}
Car-body	y_c	ψ_c	θ_c

Parameter of railway vehicle model

In this paper, track irregularities and disturbances are modelled as sinusoidal functions with the amplitude of 0.05 m, and the frequency of 1 rad/sec (0.159 Hz) for a period of 20 seconds. In order to evaluate ride comfort level of the railway vehicle, a period of 60 seconds with the frequencies of track excitation of 50.27 rad/sec (8 Hz) and 75.4 rad/sec (12 Hz) are considered using Sperling's ride index method. The numerical values of the 17-DOF railway vehicle model parameters are set based on [16] and some of the values of the parameters from [16] are assumed to be ignored. Those parameters are given in Table 2.

Table 2: Railway vehicle suspension system parameters [16]

Symbol	Value	Symbol	Value
m_c	16 803 kg	I_{cz}	41 254 kg.m ²
m_{b1-b2}	350.26 kg	$I_{b1z, b2z}$	35 kg.m ²
m_{w1-w4}	1117.9 kg	f_{11}	256.3×10^4
k_{1x}	3.9×10^5 N/m	f_{12}	221.2×10^4
k_{1y}	3.9×10^5 N/m	λ	56 000
k_{1z}	3.9×10^5 N/m	r_o	0.43 m
k_{2x}	4.5×10^3 N/m	b	1 m
k_{2y}	4.5×10^3 N/m	b_1	1 m
k_{2z}	4.5×10^3 N/m	b_3	1.4 m
c_{1x}	1.8×10^3 Ns/m	b_4	1.4 m
c_{1y}	1.8×10^3 Ns/m	L	2.6 m
c_{1z}	1.8×10^3 Ns/m	L_1	1.28 m
c_{2x}	6×10^4 Ns/m	h_1	2.36 m
c_{2y}	4.5×10^3 Ns/m	h_2	1.36 m
c_{2z}	1.8×10^3 Ns/m	h_3	1 m
I_{cy}	123 760 kg.m ²	h_4	1 m
$I_{b1y, b2y}$	105.2 kg.m ²	h_5	1 m
I_{w1-w4y}	608.1 kg.m ²		

Hafiz [17] has used the same model in his thesis and this model has been validated with the experimental model. The 17-DOF full railway vehicle derived model is closely matched the validated 17-DOF full railway vehicle model for three performance criteria; carbody lateral displacement, unwanted carbody roll angle response and unwanted carbody yaw angle response.

Simulation Results and Discussion

In order to analyse the railway vehicle body response when the suspension stiffness and damping coefficients are varied, a 0.05 m sinusoidal track irregularity with 1 rad/sec track excitation was used in the simulation. Three performance behaviours are considered in this study namely; body lateral displacement, body yaw angle and body roll angle which will be compared with suspension using the benchmark parameters as shown in Table 2. In this section, the effect of primary and secondary lateral spring, and primary and secondary

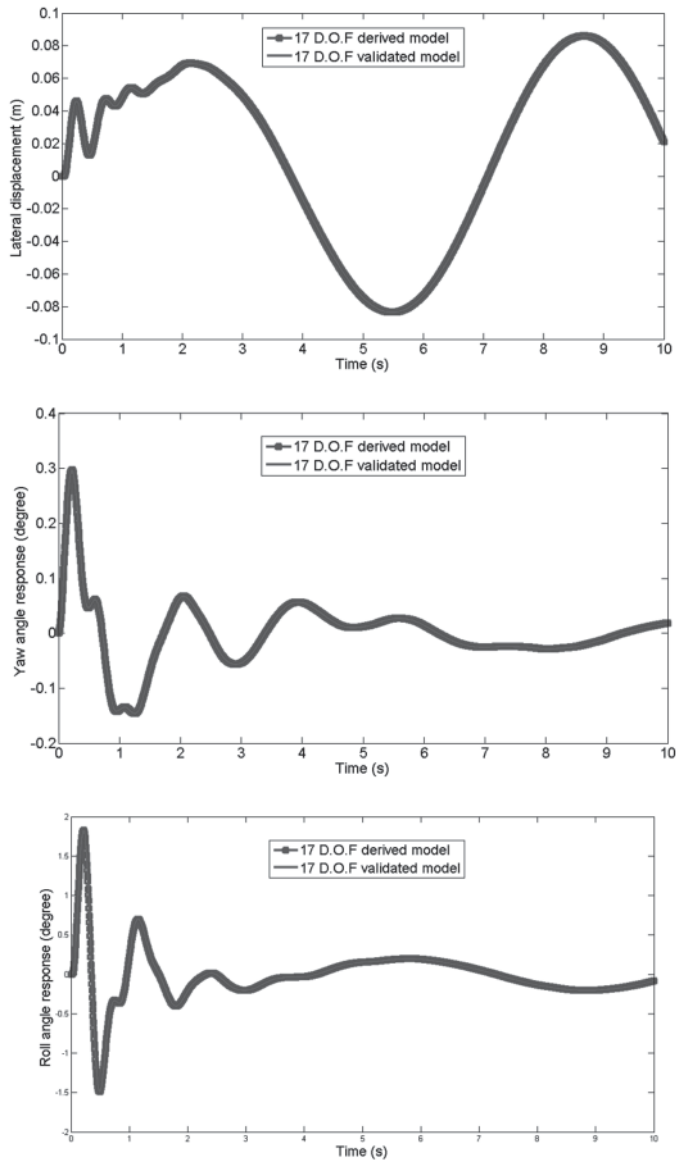

Figure 1: Verification of 17-DOF full railway vehicle derived model of unwanted carbody roll angle response for 1 rad/s excitation frequency [17] (used by permission)

lateral damper will be discussed and the best suspension parameter value will be selected as a new parameter.

Effect of primary lateral spring

Figure 2 shows the influence of the primary suspension system and the body response. The spring stiffness was varied from 1.9×10^5 to 5.9×10^5 N/m where the benchmark value is 3.9×10^5 N/m. To investigate the effect of lateral spring stiffness of primary suspension, the simulation was performed by comparing with the benchmark parameters with the values as discussed earlier. By plotting all these cases together, the relative influence of the spring can be readily seen. There are five different lines present in each figure in which the solid line represents the response of the system with the benchmark parameters, while the dashed and dotted line indicate the responses of the system with the other values.

From the figure, it can be seen clearly that by varying the spring stiffness, there is no change to the body displacement and roll angle of the railway vehicle. In the case of yaw angle, there is some effect to the vehicle body in that when the spring stiffness is increased, the amplitude of yaw angle is decreased. This is due to the fact that by increasing the value of primary spring stiffness of railway vehicle suspension, it can reduce the ability of the wheel-sets to safely negotiate large lateral irregularities. The selection method of the primary stiffness is based on a root-mean-square (RMS) value as listed in Table 3. This table lists the RMS values of the lateral, yaw and roll motions of a railway vehicle body. From the table, it can be seen that the passive suspension system of railway vehicle using 5.9×10^5 N/m primary lateral spring stiffness shows a better response compared

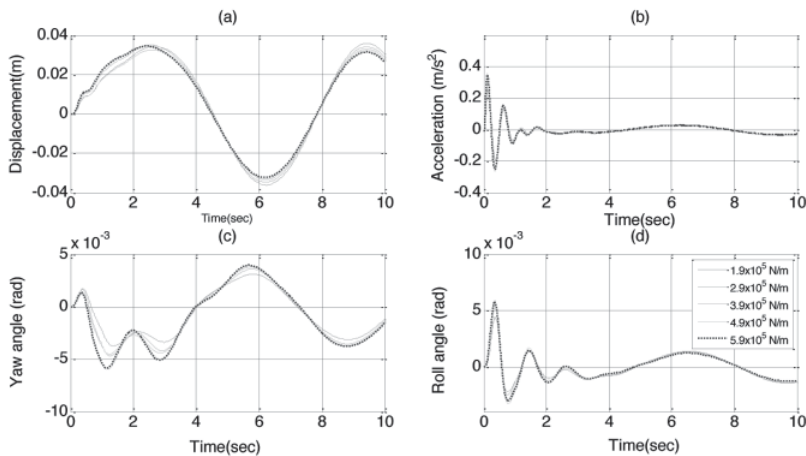

Figure 2: Effect of primary lateral spring stiffness

Table 3: RMS Value for Vehicle Motions with the Effect of Primary Spring Stiffness

Vehicle response	Primary lateral spring stiffness, k_{ly} (N/m)				
	1.9×10^5	2.9×10^5	3.9×10^5	4.9×10^5	5.9×10^5
Displacement	0.03051	0.02903	0.028	0.02728	0.02662
Acceleration	0.03014	0.02888	0.0274	0.02673	0.02672
Yaw angle	0.001171	0.001337	0.001436	0.001499	0.001541
Roll angle	0.001391	0.00133	0.001291	0.001258	0.001228

to the system with other value of stiffness especially for yaw angle response. Based on the Figure 2 and Table 3, the simulation results show that the best value among the selected parameters of primary lateral spring stiffness is 5.9×10^5 N/m and will be considered as a new suspension parameter. It means that, when increasing the primary spring stiffness, a better railway vehicle body response can be achieved.

Effect of primary lateral damper

Figure 3 illustrates the railway vehicle body responses in terms of vehicle body displacement, yaw angle and roll angle due to lateral track excitation. Five different damping coefficients have been chosen and simulated. The damping coefficients used are 0 (no damper), 2.8×10^3 , 3.8×10^3 and 4.8×10^3 Ns/m and

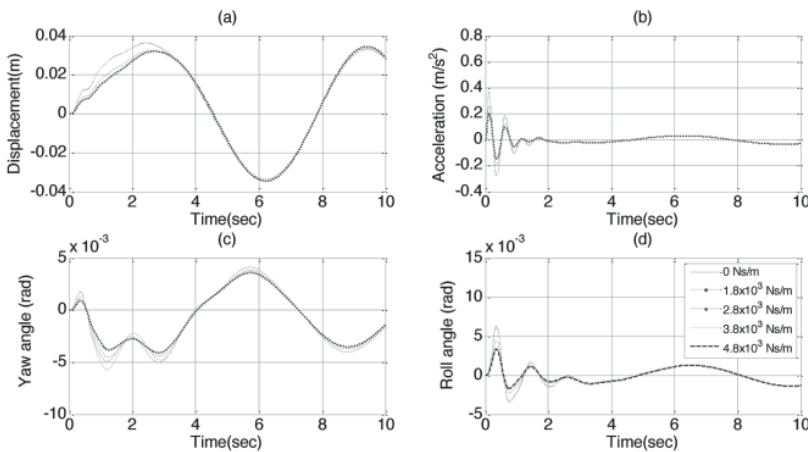

Figure 3: Effect of Primary Lateral Damping Coefficient

the benchmark value of primary suspension lateral damper is 1.8×10^3 Ns/m (refer Table 2). From the response of body displacement, body yaw angle and body roll angle, it can be clearly noted that when the damping coefficient of the primary lateral damper is increased, the response of the vehicle body decreases. According to [15], the force excitation transmitted to the vehicle body from track irregularities can be cancelled out by the primary lateral damper and at the same time the stability of the railway vehicle bogies can be improved.

Table 4 shows the RMS values of the car body lateral, yaw and roll motion of the railway vehicle with different suspension parameters. The RMS values of the car body lateral displacement with high damping coefficient are smaller than those of the passive railway suspension system, which indicate that the suspension system with higher damping coefficient possess better ride quality in terms of lateral displacement, yaw and roll angle. From Figure 2 and Table 4, it can be seen that the railway vehicle with 4.8×10^3 Ns/m primary lateral damper has better response than others and this value will be used as a new proposed parameter.

Table 4: RMS Value for Vehicle Motions with the Effect of Primary Damping Coefficient

Vehicle motion	Primary lateral damping coefficient, c_{ly} (Ns/m)				
	0 Ns/m	1.8×10^3	2.8×10^3	3.8×10^3	4.8×10^3
Displacement	0.002854	0.028	0.02823	0.02934	0.02922
Acceleration	0.02729	0.0274	0.02807	0.02898	0.002896
Yaw angle	0.001593	0.001436	0.001432	0.001379	0.00137
Roll angle	0.001328	0.001291	0.001278	0.001316	0.001296

Effect of secondary lateral spring

The effect of railway vehicle body responses after varying the secondary lateral spring can be seen in Figure 4. The spring stiffness was varied with the values of 1×10^3 , 2.5×10^3 , 6.5×10^3 and 8.5×10^3 N/m, while 4.5×10^3 N/m is the benchmark value for secondary spring stiffness. As shown in the figure, the lateral displacement of the car body is significantly lower when the lower secondary spring stiffness is used. From the figure, passenger ride comfort of the railway vehicle is improved when the value of secondary spring stiffness is 1×10^3 N/m. This is due to the effect of the secondary lateral spring since when the value of spring stiffness is decreased; the amplitude of vehicle body displacement also decreased. Table 5 summarizes the RMS values of the vehicle responses. The RMS value of the car body lateral displacement with small secondary lateral spring stiffness is smaller than those of the passive railway suspension system

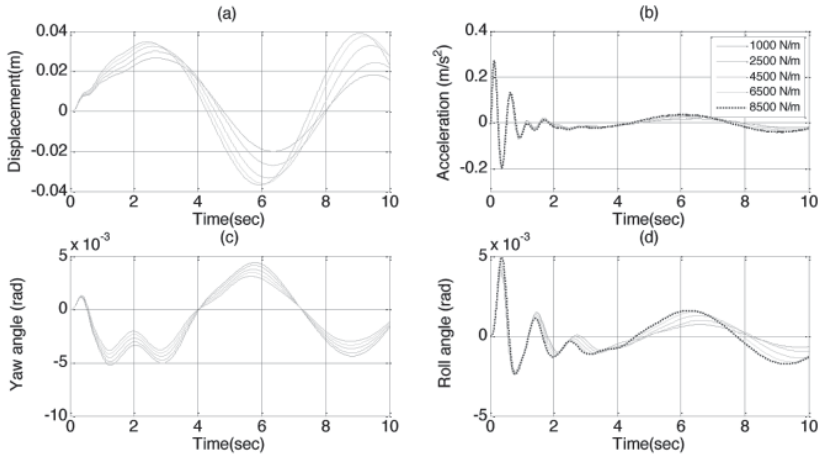

Figure 4: Effect of Secondary Lateral Spring Stiffness

Table 5: RMS Value for Vehicle Motions with the Effect of Secondary Spring Stiffness

Vehicle response	Primary lateral spring stiffness, k_{2y} (N/m)				
	1×10^3	2.5×10^3	4.5×10^3	6.5×10^3	8.5×10^3
Displacement	0.01605	0.02203	0.028	0.0275	0.02354
Acceleration	0.01642	0.02182	0.0274	0.0277	0.002421
Yaw angle	0.001284	0.001371	0.001436	0.001515	0.001601
Roll angle	0.0006686	0.0009331	0.001291	0.001412	0.00131

with other stiffness. This result indicates that when the suspension system of a railway vehicle with smaller secondary spring stiffness, it provides a better response of the vehicle.

Effect of secondary lateral damper

The secondary lateral damper will play an important role in maintaining or at least reducing lateral dynamic amplitude. Figure 4 shows the effect of the secondary lateral damper on the railway vehicle dynamic performance and Table 6 summarizes the RMS values for the vehicle response. Referring to Figure 5 and Table 6, the results indicate that the parameter of secondary lateral damper c_{2y} has significant influence on the response of the railway vehicle body in terms of body displacement and yaw angle. Bigger c_{2y} leads to smaller amplitude of body displacement, body yawing angle and rolling angle. This is due to the fact that the

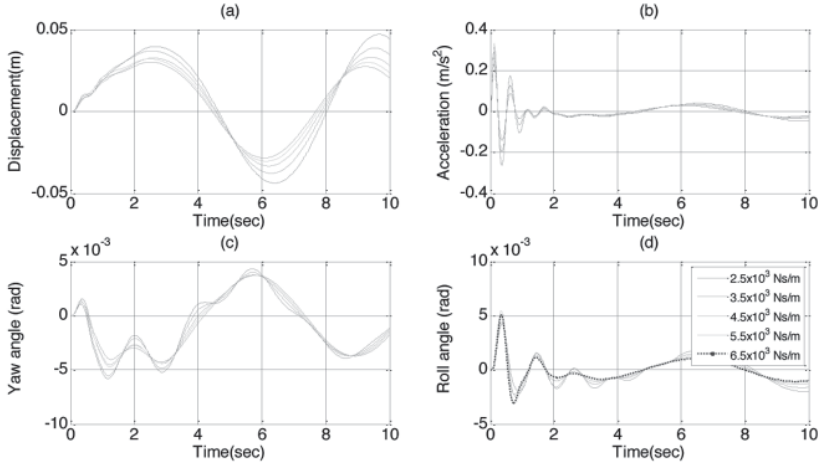

Figure 5: Effect of Secondary Lateral Damping coefficient

Table 6: RMS Value for Vehicle Motions With The Effect Of Secondary Damping Coefficient

Vehicle response	Primary lateral damping coefficient, c_{2y} (N/m)				
	2.5×10^3	3.5×10^3	4.5×10^3	5.5×10^3	6.5×10^3
Displacement	0.04461	0.03478	0.028	0.00235	0.02023
Acceleration	0.04321	0.003344	0.0274	0.0231	0.02038
Yaw angle	0.001644	0.001569	0.001436	0.001209	0.001187
Roll angle	0.001994	0.001574	0.001291	0.001098	0.0009636

secondary suspension system is designed to provide comfortable ride experience for passengers. In this case, the value of 6.5×10^3 Ns/m of secondary damper damping coefficient is selected as the proposed parameter in this study.

Benchmark and proposed parameters comparison

In order to analyze the performance of the proposed parameters, the responses of the railway vehicle dynamics are compared with the suspension system with the benchmark parameters. The proposed parameters are selected based on the optimum value of spring stiffness and damping coefficient of primary and secondary suspensions as described in the Table 3 to Table 6. The new proposed value of primary spring stiffness, k_{1y} is 590×10^3 N/m, primary damping coefficient, c_{1y} is 4.8×10^3 Ns/m, secondary spring stiffness, k_{2y} is 1×10^3 N/m, and secondary damping coefficient, c_{2y} is 6.5×10^3 Ns/m. Figure 6 depicts the

body response in terms of body displacement, body yaw angle and body roll angle of both benchmark and the new proposed values. The displacement of the vehicle body is reduced when combining all new suspension parameters while Table 7 shows the RMS values and the percentage reduction of the vehicle response. Similarly body yaw angle and roll angle, which are undesirable vehicle body motions, have the peak responses attenuated.

From Figure 6 and Table 7, it can be concluded that if the spring stiffness of the primary suspension is stiff, it will improve stability of the railway vehicle, but on the other hand it will result in poor curving performance. If a soft spring is used, curving performance will be better, but stable running is also possible only at low speed. In the case of the primary lateral damper, it also has an ability to reduce the occurrence of unwanted oscillatory motions. Typically, the selection of the optimum damping coefficient value of primary and secondary

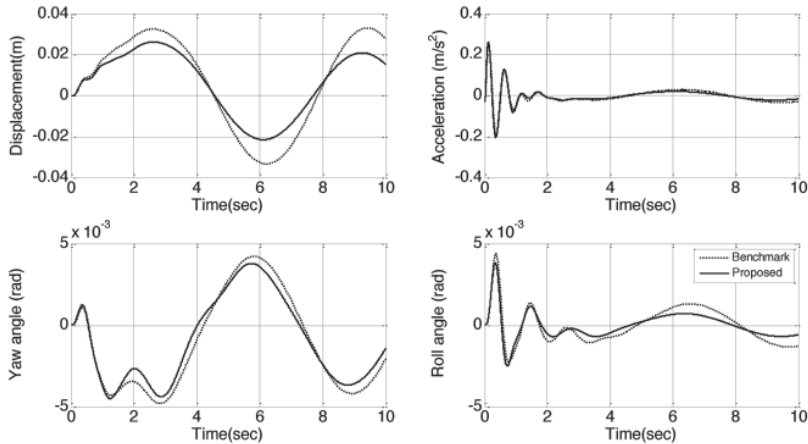

Figure 6: Comparison of Benchmark and Proposed Parameters

Table 7: RMS Value for Vehicle Motions between Benchmark and New Parameters

Vehicle response	Benchmark	Proposed	Reduction Percentage (%)
Displacement	0.028	0.01541	45
Acceleration	0.0274	0.01563	43
Yaw angle	0.002076	0.001436	63.8
Roll angle	0.001291	0.0005998	53.5

suspensions are more complicated than the choice of suspension stiffness. High levels of damping decrease the resonance amplitude of vibrations but significantly increase the acceleration acting on the vehicle body for the higher frequency input such as short wavelength track irregularities [18].

By increasing and decreasing the values of spring stiffness and damping coefficient of primary and secondary suspensions, it gives some advantages and disadvantages to the railway vehicle body responses. Although the selection is done in selecting the right springs and dampers value, inevitably some problems with ride quality will arise, meaning that it is only appropriate in certain circumstances. For example, while the train at low-speed, the railway vehicle ride quality will be at a good level if lower springs and higher dampers are selected, and vice versa. From the simulation analysis, overall it can be clearly seen that the selection of the secondary damping coefficient is more important to give a better ride quality to the railway vehicle.

The response of a railway vehicle body in terms of body displacement, acceleration, yaw and roll angle are plotted in Figure 7 and Figure 8 for 8 and 12 Hz excitation frequency. Figure 7 illustrates that the effect of the change of suspension parameters to the response of the railway vehicle body. It can be observed that the model with the new proposed parameters has better response compared to the system using benchmark parameters which the vehicle body is rather stable in its lateral direction. Under the parameters as above but with an increase in the frequency of excitation of the track, no difference in the results is found as shown in Figure 8.

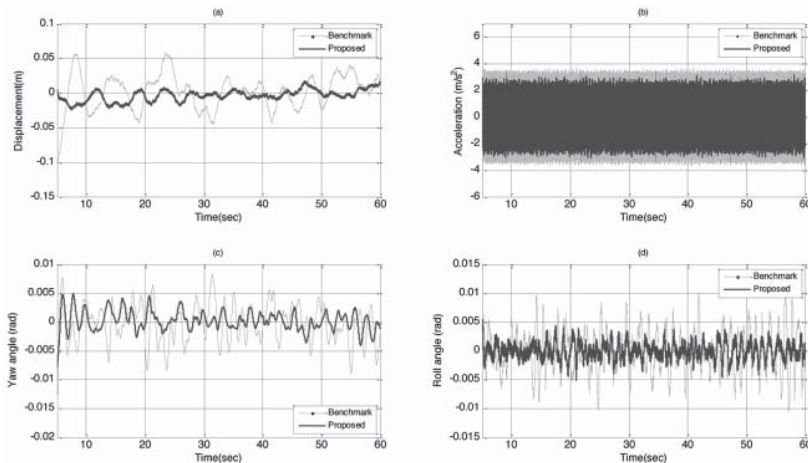

Figure 7: Body responses for 8 hz excitation frequency of the track

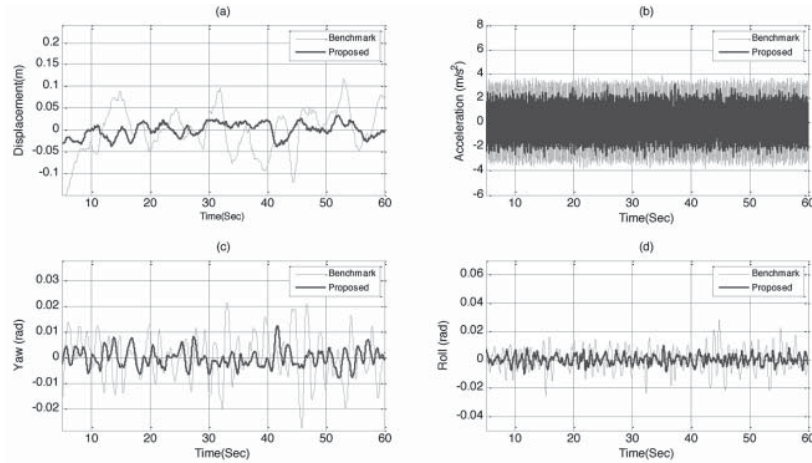

Figure 8: Body responses for 12 hz excitation frequency of the track

Ride index analysis

Railway vehicle ride index can be assessed experimentally and analytically. Sperling has introduced the ride index analysis method known as *Wz Sperling's Ride Index* and it is used to evaluate the ride quality and comfort level of a railway vehicle. Ride quality is usually interpreted as the capability of the vehicle suspension to maintain the motion within the range of human comfort, and normally for estimating ride quality of railway vehicles, the vehicle itself is judged. Ride comfort implies that the vehicle is to be assessed according to the effect of mechanical vibration on the occupants [19]. In this case, only the ride quality of the vehicle is observed since the analysis is only for the railway vehicle body, not for human body. To evaluate the ride index quality according to *Wz* factor [19], the following equations are used:

$$Wz = 0.896 \frac{a^3}{f} \sqrt[10]{10} \quad (9)$$

where a is the peak acceleration (cm/s^2), f is the oscillation frequency (Hz). Table 8 shows the ride evaluation scale for *Wz* Sperling's ride index analysis.

To calculate *Wz*, ride quality index, peak acceleration of railway vehicle body has to be taken into account to fulfil the equation (9). Table 9 shows the railway vehicle peak acceleration abstracted from the graphs in Figure 9(a) and Figure 9(b). These values are taken six times at each 10 seconds interval to get an average value in a minute. Figure 8 exhibits the ride quality index graph obtained from simulation of the railway vehicle model under a 8 and 12 Hz track excitation frequency using equation (9).

Table 8: Ride index Wz evaluation scale [18]

Ride index Wz	Ride quality
1	Very good
2	Good
3	Satisfactory
4	Acceptable for running
4.5	Not acceptable for running
5	Dangerous

Table 9: Peak acceleration of railway vehicle body

Time (sec)	8 Hz		12 Hz	
	Benchmark peak acceleration (m/s ²)	Proposed peak acceleration (m/s ²)	Benchmark peak acceleration (m/s ²)	Proposed peak acceleration (m/s ²)
10	3.414	2.723	3.027	1.48
20	3.516	2.688	2.905	1.298
30	3.513	2.591	3.215	1.909
40	3.293	2.469	3.239	1.874
50	3.557	2.765	3.155	1.973
60	3.257	2.541	3.127	1.367

The two graphs for the Figure 9 show the ride quality index of railway vehicle body analyzed within a 1 minute cycle. On average, a ride index of the vehicle body when running on track excited by 8 Hz frequency is 4.19 for benchmark parameters which is acceptable for running and a satisfactory index of 3.87 for the system using the proposed parameters. On the other hand, when the system is running on 12 Hz track excitation frequency, the ride index is 3.91 and 3.22 for both systems using benchmark and proposed parameters which are also in the satisfactory index range.

Conclusion

A complete analytical model of railway vehicle with 17 DOF that considers the effect of spring stiffness and damping coefficient of the primary and secondary

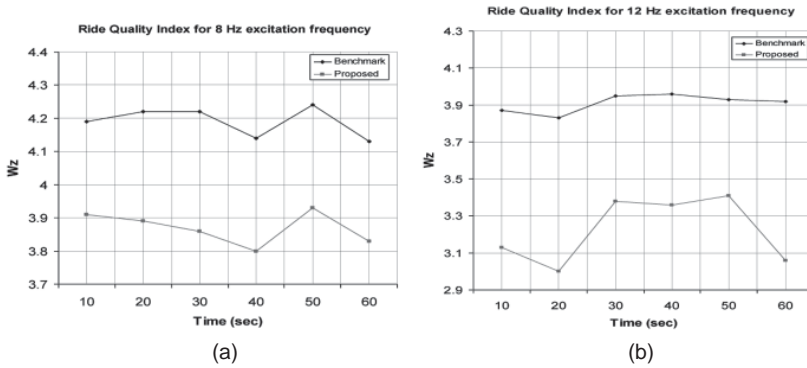

Figure 9: Ride quality index of railway vehicle body

suspension with lateral sinusoidal track irregularities has been simulated using MATLAB-Simulink software. The proposed parameters of spring and damper coefficient are compared with the system using with the benchmark parameter values. The responses of the railway vehicle are discussed in detail based on the simulation results. As for the conclusion in this study, the results of the simulation study indicated the following:

- i. When the spring stiffness of primary lateral spring is increased, the amplitude of yaw angle response is decreased; means it reduces the ability of the wheel-sets to safely negotiate large lateral irregularities.
- ii. If the damping value of primary lateral damper is increased, the response of the railway vehicle body also decreased. This is due to the fact that the primary damper with high damping value can cancel out force excitation induced by the track and at the same time can improve vehicle body response.
- iii. Increasing the secondary lateral spring stiffness results in an increasing of the body response amplitude.
- iv. A larger secondary damping coefficient leads to smaller amplitude of the body response. Increasing the secondary lateral damping ratio results in a decrease in the car body lateral displacement, yaw angle and roll angle. This is due to the fact that the secondary lateral damper is designed for comfortable and safety purposes.

By comparing the simulation results, it can be concluded that the stability of a railway vehicle can be improved by focusing on the primary suspension system, while better passenger ride comfort can be achieved through various modifications on secondary suspension system. Further, application of active or semi-active system to the secondary suspension could be a good solution to solve the induced vibration problem which occurs in railway vehicles. On the

other hand, passive suspension system can also be used which is a less costly solution but with a lower performance.

Acknowledgement

This work is supported by the Ministry of Education (MoE) of Malaysia through its scholarship and financial support. The support from Universiti Teknologi Malaysia (UTM) through Research University Grant entitled “Development of Magnetorheological Damper for Improving Ride Comfort of Railway Vehicle” Sub Project No: 08J47 and Universiti Teknikal Malaysia Melaka (UTeM) through laboratory facilities is also gratefully acknowledged.

References

- [1] S. Sezer, S. Cetin, and A. E. Atalay. (2011). “Application of Self Tuning Fuzzy Logic Control to Full Railway Vehicle Model”, *Procedia Computer Science*, 6(1), 487-492.
- [2] H. R. O'Neill and G. D. Wale. (1994). “Semi-active Suspension Improves Rail Vehicle Ride”, *Computing & Control Engineering Journal*, 5, 183-188.
- [3] Y. Shin, W. You, H. Hur, and J. Park. (2012). “Semi-active Control to Reduce Carbody Vibration of Railway Vehicle by using Scaled Roller Rig”, *Journal of Mechanical Science and Technology*, 26(11), 3423-3431.
- [4] M. Zapateiro, F. Pozo, H. R. Karimi, and L. Ningsu. (2012). “Semiactive Control Methodologies for Suspension Control with Magnetorheological Dampers”, *IEEE/ASME Transactions on Mechatronics*, 17(2), 370-380.
- [5] K. Hudha, Harun, M. Hafiz., Harun, M. Hanif., and Jamaluddin, H. (2011). “Lateral Suspension Control of Railway Vehicle using Semi-Active Magnetorheological Damper”, in *Proceedings of the IEEE Intelligent Vehicles Symposium (IV)*, Baden Baden, Germany, pp. 728-733.
- [6] Z. Yang, B. Zhang, J. Zhang, and C. Wang. (2011). “Research on Semi-active Control of High-speed Railway Vehicle Based on Neural Network-PID Control”, in *Seventh International Conference on Natural Computation (ICNC)*, pp. 673-676.
- [7] S. Alfi, S. Bruni, G. Diana, A. Facchinetti, and L. Mazzola. (2011). “Active Control of Airspring Secondary Suspension to Improve Ride Quality and Safety against Crosswinds”, *Proceedings of the Institution of Mechanical Engineers, Part F: Journal of Rail and Rapid Transit*, 225(1), 84-98.

- [8] M. Metin, and R. Guclu. (2011). "Active Vibration Control with Comparative Algorithms of Half Rail Vehicle Model under Various Track Irregularities", *Journal of Vibration and Control*, 17(10), 1525-1539.
- [9] A. Orvnäs, S. Stichel, and R. Persson. (2011). "Active Lateral Secondary Suspension with H_∞ Control to Improve Ride Comfort : Simulations on a Full-Scale Model", 49(9), 1409-1422.
- [10] A. Orvnäs. (2011). "On Active Secondary Suspension in Rail Vehicles to Improve Ride Comfort " PhD Thesis, Dept. of Aeronautical and Vehicle Engineering, KTH Engineering Science.
- [11] A. Mohan and M. Ahmadian. (2004). "Nonlinear investigation of the effect of primary suspension on the hunting stability of a rail wheelset", in *Proceedings of the 2004 ASME/IEEE Joint Rail Conference*, Baltimore, Maryland, pp. 53-61.
- [12] G. S. Gao and S. P. Yang. (2006). "Semi-active Control Performance of Railway Vehicle Suspension Featuring Magnetorheological Dampers", in *IST IEEE Conference on Industrial Electronics and Applications*, pp. 1-5.
- [13] Y. Sugahara, A. Kazato, T. Takigami, and R. Koganei. (2008). "Suppression of Vertical Vibration in Railway Vehicles by Controlling the Damping Force of Primary and Secondary Suspensions", *Quarterly Report of RTRI*, 49, 7-15.
- [14] A. Benedetto, L. Pugi, V. Colla, F. Bartolini, and F. Cangioli. (2011). "Design and Optimization of a Semi-active Suspension System for Railway Applications", *Journal of Modern Transportation*, 19(4), 223-232.
- [15] A. H. Wicken. (2006). "A History of Railway Vehicle Dynamics", in *Handbook of Railway Vehicle Dynamics*, S. Iwnicki, Ed., ed London: CRC Press Taylor & Francis Group, pp. 5-40.
- [16] S.-Y. Lee and Y.-C. Cheng. (2008). "A New Dynamic Model of High-Speed Railway Vehicle Moving on Curved Tracks", *Journal of Vibration and Acoustics*, 130, pp. 011009-011009.
- [17] Harun, M. Hafiz. (2013). "Improvement of Railway Vehicle Dynamics Performance using Semi-active Secondary Suspension", Master Thesis, Universiti Teknikal Malaysia Melaka.
- [18] Anna Orlova and Y. Boronenko. (2006). "The Anatomy of Railway Vehicle Running Gear", in *Handbook of Railway Vehicle Dynamics*, S. Iwnicki, Ed., ed London: CRC Taylor & Francis, pp. 39-84.
- [19] K. G. Vijay and V. D. Rao. (1984). *Dynamics of Railway Vehicle Systems*. United Kingdom: Academic Press, Inc. (London) Ltd.

Appendix 1

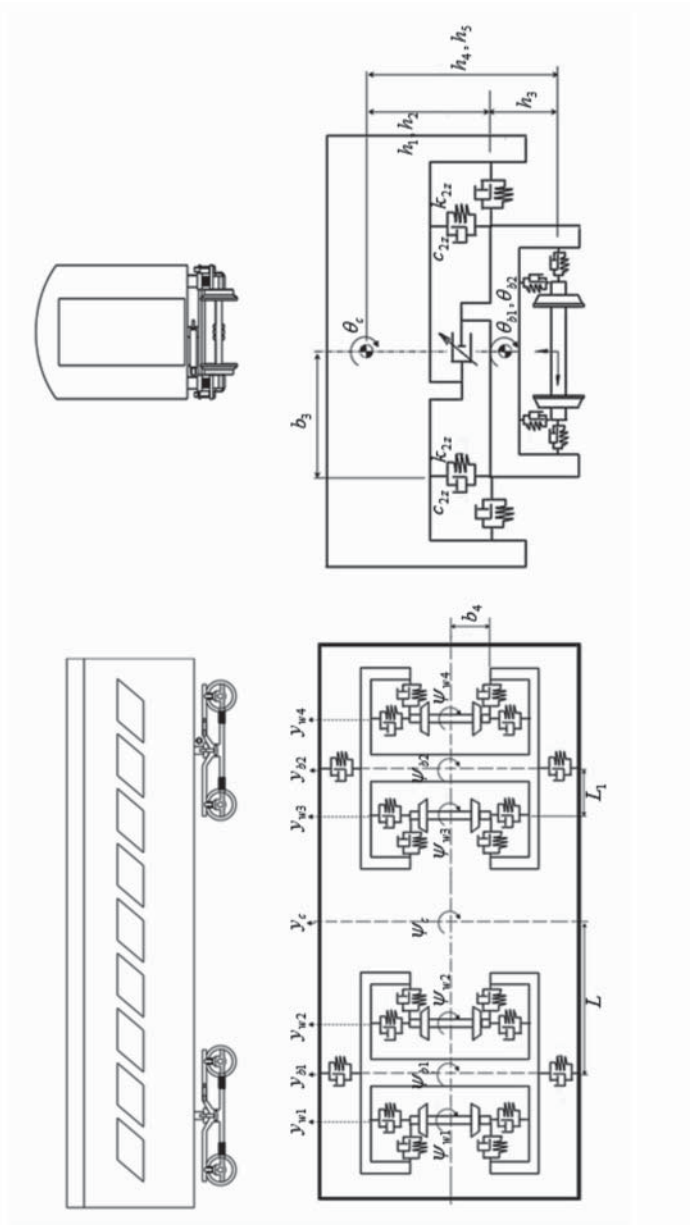

Orthographic view of 17-DOF railway vehicle dynamic model

Appendix 2

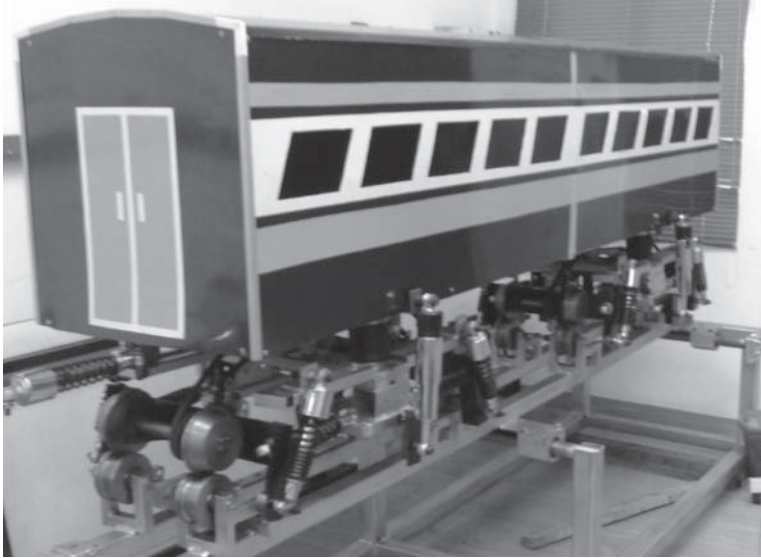

Small scale railway vehicle test rig